



WHAT DO YOU HAVE TO SAY?



HP Indigo W7200 Digital Press

Application-focused, offset quality with high volume digital productivity

- 1 Attention lights:
Allow operator to monitor multiple presses without remaining in immediate vicinity
- 2 External blanket heating:
Accurate local temperature control optimizing print process per substrate type
- 3 Charge roller
- 4 Binary Inking Developers (BID's)
- 5 Rewinder
- 6 In-Line Densitometer (ILD):
Dual engine synchronized system assures color consistency, fidelity, dot gain compensation and accurate repeatability across jobs, and between engines. Motorized ILD enables self-calibration and optimized color calibration
- 7 Internal buffering system
- 8 Buffering Control Unit (BCU):
Enables printing different number of separations on each print engine in the highest productivity. The unit includes inspection table, buffering, turn bar & web guide
- 9 Touch screen user interface:
Intuitive and easy-to-use remote assistance diagnostic & resolution tools. Entire press can be operated from user panel on either engine
- 10 One-shot process:
Assures perfect color registration by accumulating all image separations on the blanket and transferring them to the substrate simultaneously in one shot

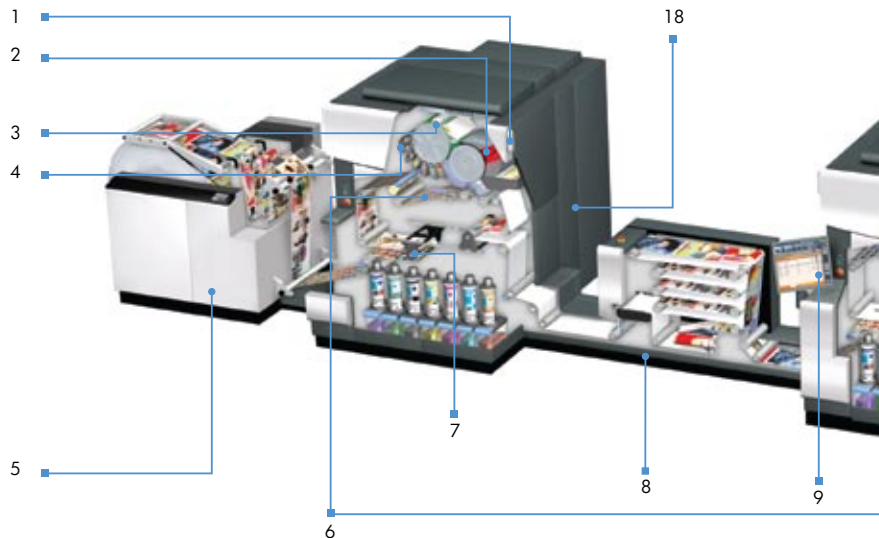

Accelerate your business with new application opportunities

- Deliver on-demand, short-run books, journals, manuals, yearbooks and magazines with unmatched offset quality
- Print high-impact, high-volume personalized direct marketing campaigns in full color
- Produce revenue-building, attention-grabbing trans-promo statements

The new twin-engine, continuous feed HP Indigo W7200 Digital Press clearly raises the bar for digital productivity, while setting you apart competitively with outstanding offset quality. Building on the success of the HP Indigo press w3250, the new HP Indigo W7200 Digital Press includes features requested by existing commercial web customers.

A powerful combination: fast, offset quality for high volume runs

The HP Indigo W7200 Digital Press is the premier digital solution for adding high productivity and true offset quality for large volume, highly variable “every page is different” production runs. It’s a powerful combination available only from HP Indigo.

Operating at throughput speeds of 240 full-color images per minute and 960 one-color images, the HP Indigo W7200 Digital Press produces over 7.5 million color images per month. With an architecture and toolset built for high productivity and reliability, you can meet the tightest deadlines and the toughest mission-critical requirements.

As in all HP Indigo digital presses, HP ElectroInk liquid ink is the proprietary underlying technology delivering proven offset and photo quality from the HP Indigo W7200 Digital Press—and your distinct quality advantage compared to other digital presses. You can produce CMYK process color jobs with an

extensive color gamut, and achieve PANTONE® emulation with 4, 6 and 7 colors mixed on-press. You can also create special spot colors off-press—using the exclusive HP Indigo Ink Mixing System—to accurately match your clients’ corporate branding and custom color requirements. On-press Fast Ink Replacement technology enhances productivity by letting the operator switch spot color inks while the press is running.

Deliver a broad range of jobs for a dynamic marketplace

With its robust productivity, the HP Indigo W7200 Digital Press gives you the ability to address a wider range of long run jobs. You can offer your customers a variety of value-added services and applications, such as print-on-demand services for books, journals and manuals, as well as VDP capabilities for personalized direct marketing, self mailers, inserts, postcards and trans-promo statements.

Without any compromise in productivity, the HP Indigo W7200 Digital Press supports substrates with thicknesses from 27 lb. text—to satisfy requests for the lightest papers—up to 130 lb. cover, including coated, uncoated and recycled stock. By supporting an image format of 12.5"x38.6", the press increases your ability to run more jobs and new applications not previously possible, with cost effective, highly efficient page imposition and media use.

The HP Indigo W7200 Digital Press removes design and production barriers offering customers greater graphic and artistic creativity. It supports jobs with the high ink coverage—regardless of color—with finely detailed, highly accurate quality. You can meet requests for monochrome up to 7 colors, as well as spot and highlight color—during a single run without stopping or changing settings.

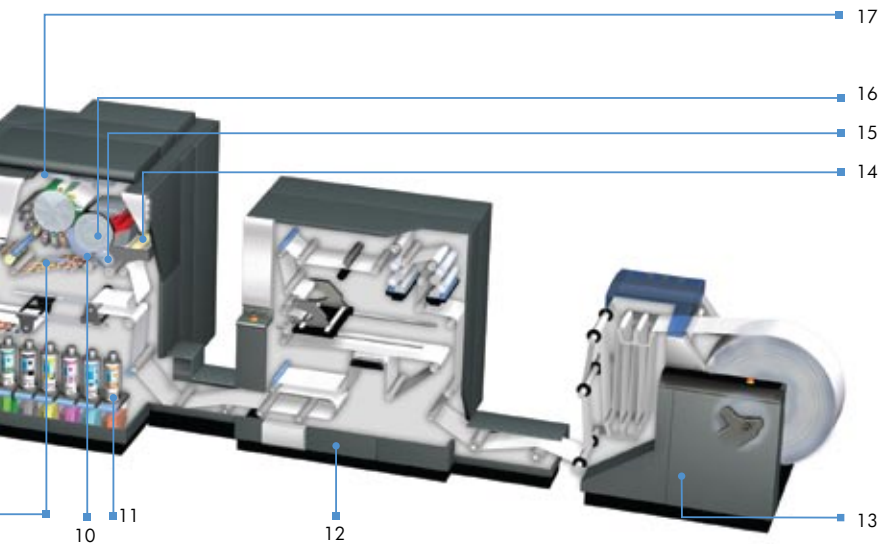

- 11 Ink cabinet:
 - Liquid ElectroInk achieves best-in-class print quality
 - 7color stations allow Pantone emulation of 4, 6, 7 process colors and spot colors
 - On-the-fly On-press Fast Ink Replacement (OFIR) system
 - Enlarged ink cans
- 12 In-Line Priming Unit (ILP):
 - Enables the use of a wide substrate range including: commodity coated, uncoated and recycled papers
- 13 Unwinder
- 14 Blanket Cleaning Station (BCS)
- 15 Impression cylinder
- 16 Blanket cylinder:
 - Supports high print speed, wide substrate gamut and 38.6" long format
- 17 High speed writing head:
 - 812dpi (8 Bit/pixel) at 775 Mpix/sec using a 22 beam laser
- 18 Imaging oil recycling system:
 - Limits environmental footprint by reducing oil consumption as well as waste

The HP SmartStream Production Pro is a robust off-press Digital Front-End (DFE) that manages and drives jobs to the HP Indigo W7200 Digital Press—which runs at full speed. Controlled from a centralized prepress or IT location, it uses lights out automation and scalability to balance print loads among multiple presses. With expandable computing power and storage space, it gives you ample capacity for driving the press 24/7 while prepress operators are not in the shop. This DFE also supports the most common industry standard file formats, including PDF, PPML and AFP/IPDS.

Anchored by the HP Indigo W7200 Digital Press, your customized, end-to-end solution includes optimized third-party hardware and software offerings. When producing brochures and postcards, you can apply inline UV coating, punching and corner rounding. For books and manuals, the press quickly delivers stacked, bind-ready book blocks without operator intervention. Whether you're running roll-to-roll or roll-to-sheet production, you can select from several industry-proven inline or near-line finishing solutions.

Low total cost of ownership = increased profits

HP Indigo offers extremely attractive programs that lower variable charges as your volumes increase—and the price per page is not dependent on ink coverage. Pricing for monochrome printing is highly competitive as well, increasing your business profitability.

Your media costs remain low with an In-Line Priming system (ILP) on the HP Indigo W7200 Digital Press that allows you to order a broad range of standard, affordable substrates.

And of course, HP offers attractive financing options and flexible terms that facilitate the acquisition of your press.

Trans-promo marketing makes a big statement

The HP Indigo W7200 Digital Press is tailor-made to take advantage of profitable growth opportunities, such as trans-promo statements. It offers the added value of exceptional offset quality at high speeds, while enabling personalized, one-to-one marketing to individual recipients. In an industry that depends heavily on data integrity, the HP Indigo solution assures reliable data with its AFP/IPDS drivers.

Oniya Shapira, of Asseret, Israel, uses six HP Indigo web-fed presses to produce monthly credit card bills for Cal, a large Israeli credit card issuer. With its digital flexibility and offset quality, Oniya Shapira helps Cal personalize each statement with colorful, attention-getting advertisements for products or stores, each tailored to individual customer preferences.

Print-on-demand books reduces cost and waste

The HP Indigo W7200 Digital Press lets you take advantage of the expanding market for short-run, print-on-demand books, journals and magazines. The end-to-end solution combines high productivity and offset quality with broad substrate support, inline finishing that delivers stacked, bind-ready book blocks and optimized partner solutions that enable fully automated matching and binding. You'll also benefit from cost-efficient monochrome book and journal block production.

Lightning Source Inc. prints and ships over 1.2 million books per month for over 5,000 publishers around the globe. For publishers that use Lightning Source print and distribution solutions, a book order submitted in the morning will be processed, printed and shipped the same day. To meet the demand for quick turnaround, Lightning Source uses HP Indigo w3250 web presses with customized solutions for in-line cutting and stacking to produce color book interiors at speeds of up to 136 four-color pages per minute eliminating excess cost and waste.

Technical specifications

Printing speed	14,400 4-color pages per hour 28,800 2-color pages per hour 57,600 1-color pages per hour
Image quality	812 and 1219 dpi at 8 bit 2,438 x 2,438 addressability HDI (High Definition Imaging) Line screen: 144, 175, 180
Image size	12.48" x 38.58" max
Paper format	Max. web width: 13.4" Min. repeat length: 18.9" (in 4-color print mode) Max. repeat length: 38.6"
Paper weight	Roll-to-roll: 27 lb text – 130 lb cover (subject to paper stiffness) Roll-to-sheet: 27 lb text – 110 lb cover (subject to paper stiffness)
Paper input system	Input roll max. diameter: 51.2" Input roll inner core diameter: <ul style="list-style-type: none">• Standard: 3"• Optional: 6"
Press dimensions (including in-line priming and unwinder)	Length: 38 ft. 8" Width: 7 ft. 6" Height: 6 ft. 10"
Press weight (including in-line priming and unwinder)	15,653 lb.
Optional equipment/configuration:	
Expanded color capabilities	HP IndiChrome 5, 6 and 7-color printing HP IndiChrome Ink Mixing System
Paper output system	Rewinder: Hunkeler Rewind RW6 Cutting and offset stacking: Hunkeler POPP6 Or other customized solutions according to the customer's need

North America

Hewlett-Packard Company
Summit Boulevard 1001
Mailstop 401
Atlanta, GA 30319
USA
Tel: +1 800 289 5986
Fax: +1 404 648 2054

Europe, Middle East and Africa

Hewlett-Packard Company
Renier Nafzgerstraat 100
KL Maastricht 6221
The Netherlands
Tel: +31 43 356 5656
Fax: +31 43 356 5600

Asia Pacific

Hewlett-Packard Company
Depot Road 138
Singapore 109683
Tel: +65 6727 0777
Fax: +65 6276 3160

Latin America

Hewlett-Packard Company
Blue Lagoon Drive 5200
Suite 950
Miami, FL 33126
USA
Tel: +305 267 4220
Fax: +305 265 5550
informahpindigo@hp.com

Israel

Hewlett-Packard Company
Kiryat Weizmann
P.O. Box 150
Rehovot 76101
Israel
Tel: +972 8 938 1818
Fax: +972 8 938 1338

To learn more, visit www.hp.com/go/graphic-arts or
www.hp.com/go/myhpindigoweb

© 2008 Hewlett-Packard Development Company, L.P. The information contained herein is subject to change without notice. The only warranties for HP products and services are set forth in the express warranty statements accompanying such products and services. Nothing herein should be construed as constituting an additional warranty. HP shall not be liable for technical or editorial errors or omissions contained herein.

PANTONE® and other PANTONE, Inc. trademarks are the property of PANTONE, Inc
4AA1-7735ENUS, September 2008. This is an HP Indigo digital print.

